

# MARKETAIR, INC.

Phone: (732) 985-8226

Fax: (732) 985-2134

www.marketair.com

info@marketair.com

## INSTALLATION INSTRUCTIONS FOR EASY PLENUM

Models: EPM-3, EPM-4, EPU-2, EPU-3, EPU-4, EPU-5

JANUARY 9, 2023

### WARNING:

**AFTER CUTTING REAR SURFACE OF PLENUM AS REQUIRED TO INSTALL ADAPTER COUPLING AND MODIFYING COLLARS TO SUIT DUCT SIZES REQUIRED, CAREFULLY VACUUM INTERIOR OF PLENUM TO REMOVE ANY POLYSTYRENE DUST OR SCRAPS**

1. Measure the outside dimensions of the fan outlet on the air handler. ( L X H, Fig 1.) Add 1/8" to width and height to allow for the thickness of the Aluminum TEE adaptor coupling and mark the cut out required on rear surface of plenum (White dotted area, Fig. 2).

Using a jigsaw, hot wire cutter or a sharp utility knife cut out the marked area.

Discard the surplus material and vacuum inside plenum to remove any cutting debris.

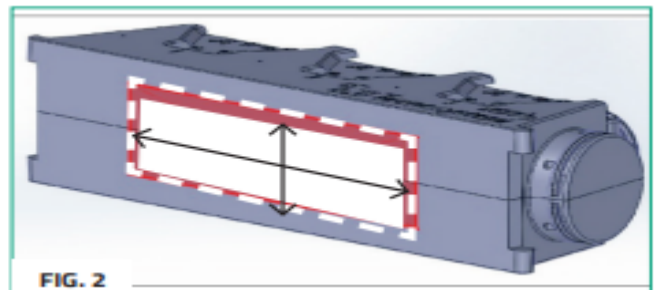
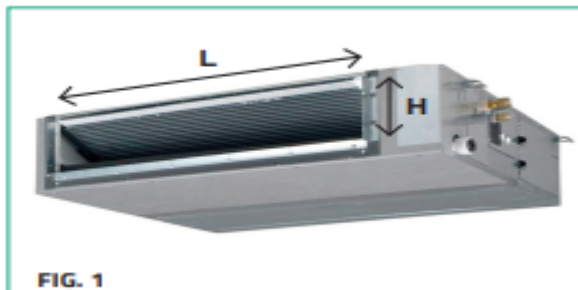

2. Cut the Aluminum TEE profiles (included in the kit) to the length required to create the adapter coupling, however before cutting, make sure that the finished adapter coupling will fit over the fan outlet flange on the air handler.
3. Using the adhesive (included in the kit), attach the cut lengths of Aluminum channel to the 4 sides of the orifice on the rear of the plenum and seat them securely by tapping them firmly into place. (Fig. 3).

Allow the adhesive to set for at least 2 minutes.

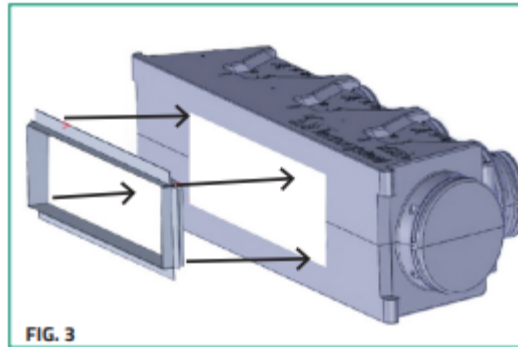

4. Apply the adhesive foam sealing gasket (included in the kit) to the front surface of the air handler continuously around the perimeter of the fan outlet (Fig. 1).
5. Determine how many duct outlets are needed, and, using a jigsaw, hot wire cutter or sharp utility knife, modify the collars to accept the duct sizes required.
  - For 6" duct, simply remove the end caps on the collars.
  - For 8" duct, detach the section which contains the 6" collar from the 8" collar (as indicated by the arrows in Fig. 4.)

Discard the surplus material and vacuum inside plenum to remove any cutting debris.

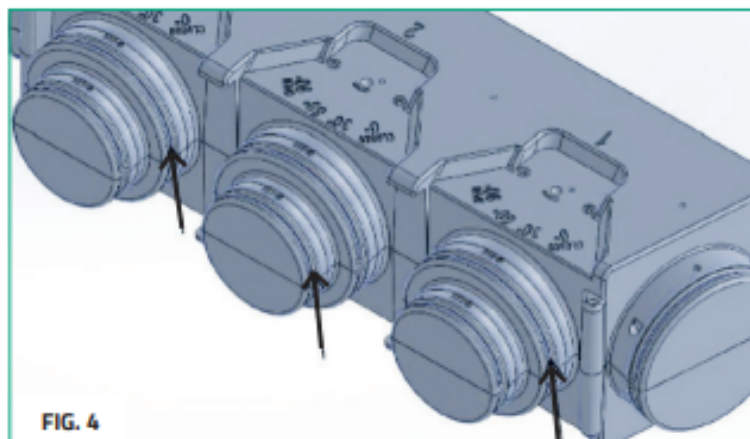

Push the adaptor flange on the rear of the plenum over the fan outlet flange on the air handler and ensure that the edge of the adaptor flange is seated on the gasket to ensure a good seal.

Attach the plenum firmly to the air handler with 3 or 4 equally spaced sheet metal screws on both top and bottom of adaptor flange.

6. If supplementary support is required for the plenum, it can be hung from the underside of the deck by using 2 ½" all thread rods which can be screwed directly into the molded holes at the 2 front corners of the plenum.